

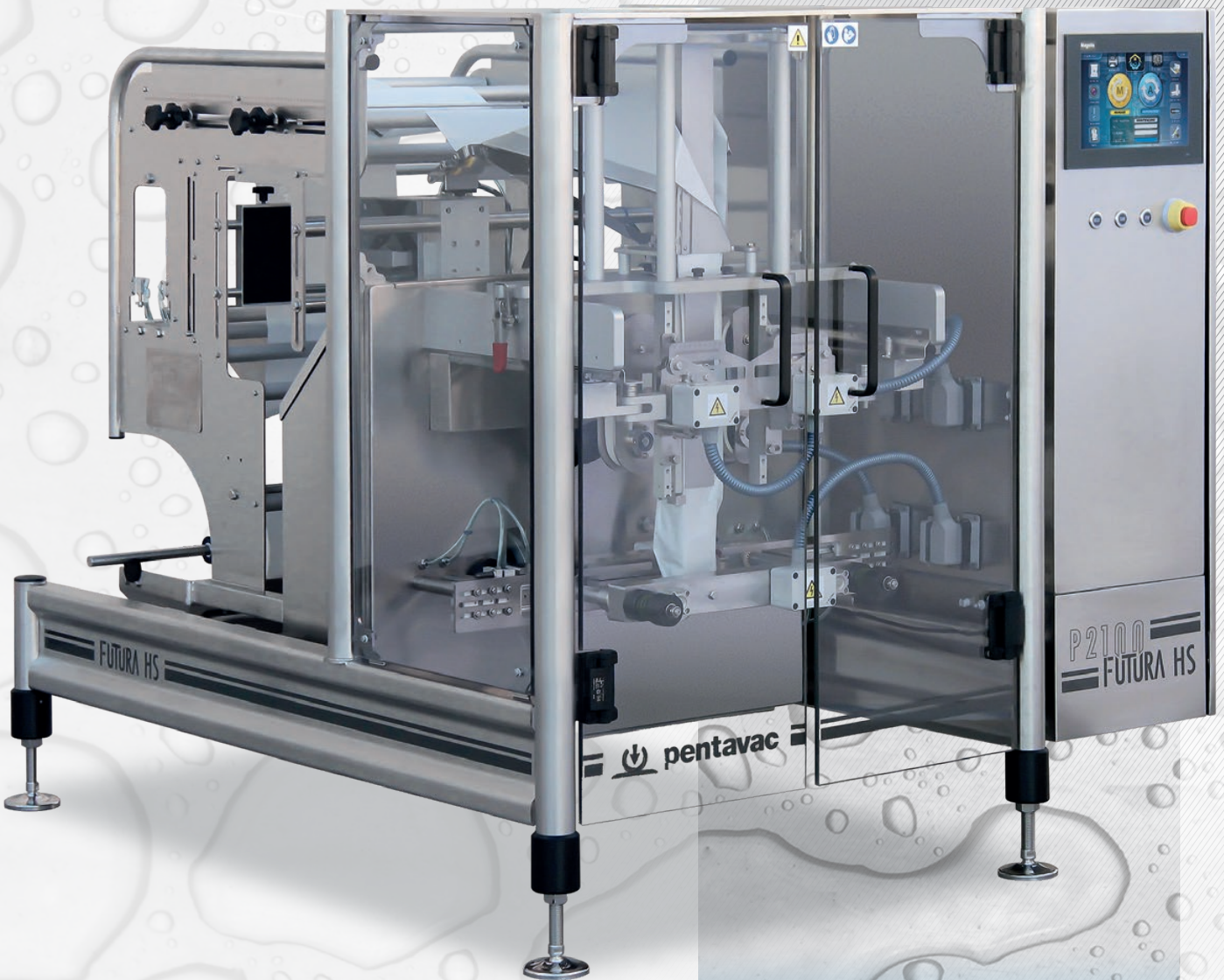

more than P2100 reasons to rely on FUTURA

inox version



P2100
FUTURA HS

 La P2100, best seller di famiglia, si evolve e presenta la 6° serie: FUTURA. La versione HS ha acquisito maggiore potenza di saldatura garantendo performance superiori, oltre a risparmi energetici e silenziosità.

Affidabilità, semplicità e robustezza sono sempre state le basi salde del nostro modello di punta.

Il design del nuovo telaio è stato studiato accuratamente per facilitare e ottimizzare le operazioni di pulizia e per alloggiare i colletti formatori per il sempre più diffuso film carta riciclabile.

L'interfaccia operatore è costituita da un nuovissimo PC panel da 12" customizzato per controllare confezionatrice, sistema di dosaggio e stampante da un unico HMI.

La P2100 FUTURA è innovazione ma è anche tradizione: è il frutto dell'esperienza maturata negli oltre 25 anni dell'azienda ed è destinata a delineare il presente ed il futuro della Pentavac.

 P2100, the best seller of the family, has evolved and now presents its 6th series: FUTURA. The HS version has acquired more sealing power securing higher performances in addition to energy savings and noiselessness.

Reliability, simplicity and strength have always been the well-founded bases of our leading model.

The design of the new frame has been carefully studied to ease and optimize cleaning operations and to accommodate the forming collars for the increasingly widespread recyclable paper film.

User interface is made of a brand new 12" PC panel customized to control packaging machine, dosing system and printer from one unique HMI.

P2100 FUTURA is innovation yet it is also tradition: it is the result of the experience gained during over 25 years of company activity and it is intended to delineate Pentavac present and future.

 La P2100, best seller de famille, s'évolute et présent sa 6^{ème} série: FUTURA. La version HS a acquis majeure puissance de scellage en garantissant performances supérieures au-delà des économies énergétiques et du silence.

Fiabilité, simplicité et robustesse ont toujours été les fondations solides de notre modèle de pointe.

Le design du nouveau châssis a été soigneusement étudié afin de faciliter et optimiser les opérations de nettoyage et pour loger les conformateurs pour le plus en plus répandu film papier recyclable.

L'interface utilisateur est formée d'un tout nouveau panel PC de 12" personnalisé pour contrôler l'ensacheuse, le système de dosage et l'imprimeur dans un seul HMI.

La P2100 FUTURA est innovation mais aussi tradition: c'est le fruit de l'expérience tirée pendant plus de 25 ans d'activité et est destinée à définir le présent et le future de Pentavac.

Dimensioni busta

Bag sizes

Dimensions du sachet

Min. mm 32 (w) x 60 (l)

Max mm 320 (w) x 400 (l)

(depending on machine height)

Velocità - Speed - Vitesse

Up to 80 bags/min

(mechanical speed 110 bags/min)

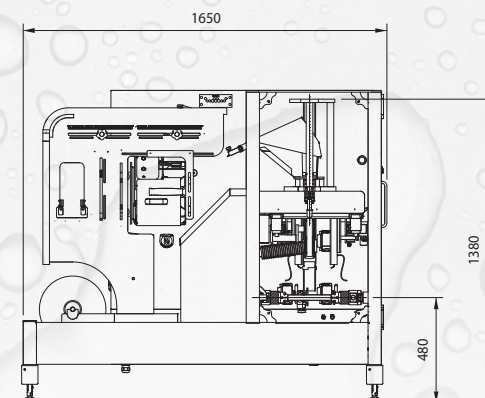
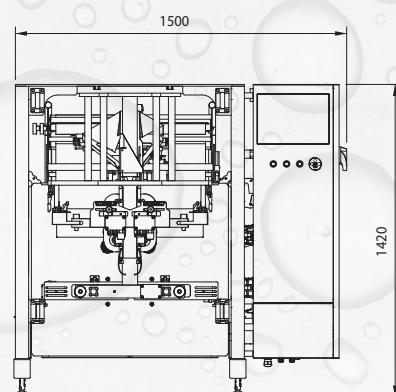

TIPI DI CONFEZIONE - TYPE OF BAGS - TYPES DE SACHETS



Confezione a cuscino
Pillow bag
Sachet à coussin



Confezione a soffietto
Gusseted bag
Sachet à soufflet



Confezione a fondo quadro
Block bottom bag
Sachet à fond carré



Confezione a 4 saldature stabilo
4 side seal stabilo bag
Sachet à 4 soudures stabilo